

Surface Crystallography Spectrometer - IntegraLEED

based on Low Energy Electron Diffraction (LEED) and Auger Electron Spectroscopy (AES)

MODEL LEED 600 (BDL600IR) with Integral Retraction and Shutter

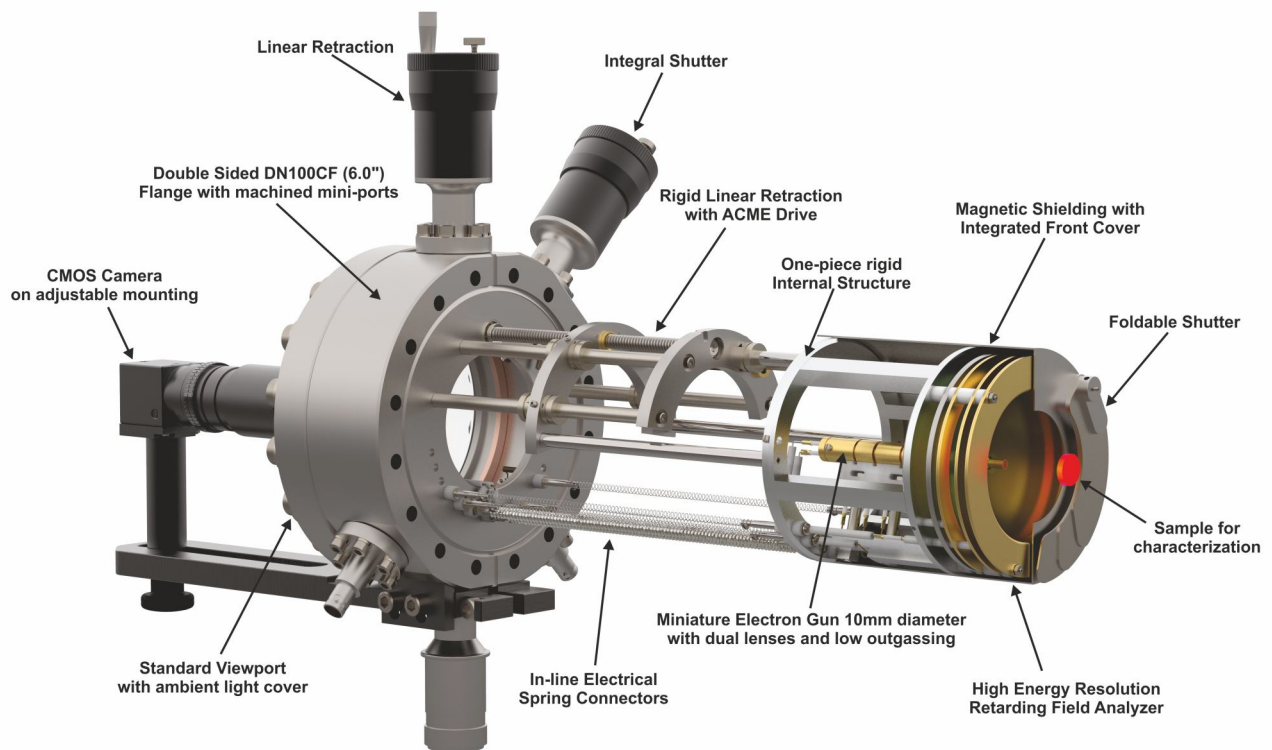

Features:

- High angular & energy resolution LEED & AES
- Miniature Electron Gun with double focusing
- Superior magnetic shielding
- Moiré pattern reduction
- Suitable for “in situ” epitaxial growth
- Integral Linear Motion and Shutter
- Low Outgassing Rate
- Easy add-on AES

Applications

Compact size and high performance characterization tool for surface crystallography of single crystals and “in-situ” epitaxy.

The LEED 600 is capable of providing LEED and AES data for a wide range of samples.

The compact instrument size allows for easy installation to smaller UHV systems.

Materials suitable for characterization should be single crystals and epitaxial films in categories such as: 2D materials, semiconductors, metals, oxides and magnetic films.

IntegraLEED - MODEL LEED 600

Specifications

LEED-AUGER OPTICS (Model BDL600IR)

Retarding Field Analyzer	Concentric assembly of hemispherical grids Working distance from sample 15 mm
Grid Material	Gold coated St-Steel wire mesh (100 mesh, 81% transparency)
Energy Resolution	0.2% - 0.5% at low modulation volt.
Glass-Display	Fused silica glass coated with indium-tin oxide conductive layer and P31 phosphor (ZnS:Ag:Cu-green, 525 nm wavelength) 93° angle of acceptance from sample at a distance of 50 mm
Monitoring	Standard viewport on DN100CF (6" CF) Flange
Linear Motion	Up to 150 mm retraction from sample (100 mm standard); linear ball bearing and acme thread with all spring electrical connections
Integral Shutter	Open and close at any position of the linear motion
Magnetic Shielding	Mu-metal cylinder with front cover for maximum magnetic field attenuation
Assembly	Extreme-high-vacuum compatibility with stainless steel, high alumina and gold-plated copper alloy materials
Mounting	DN100CF(6"CF) double sided conflat flange with port length range 145 mm - 500 mm
Bakeability	Under vacuum, 250°C maximum

Integral Miniature Electron Gun

Beam Energy	LEED 5 eV to 750 eV AES 5 eV to 3000 eV
Beam Current	LEED 2 μ A at 100 eV and 0.5 mm beam size AES up to 100 μ A at 3 keV
Beam Size	from 1 mm to 250 μ m - adjusted by wehnelt voltage
Electron Source	Tungsten-2%Thoriated filament standard, single crystal LaB6 filament optional
Energy Spread	0.45 eV (thoriated-tungsten filament)
Overall Size	10 mm lens diameter and 80 mm length

Ordering Guide

LEED Application:

BDL600IR	LEED optics with integral electron gun on 6" flange - 3 Grids
LMX	Linear motion (X=retraction distance)
ISH	Integral shutter
LPS075-D	Digital power supply with voltage range 0 - 750 V
LIM12	LEED imaging software with CMOS camera, full version (optional)
LIM12B	LEED imaging software with CMOS camera, basic version (optional)

LEED and AES Application:

BDL600IR	LEED optics with integral electron gun on 6" flange - 4 Grids
LMX	Linear motion (X=retraction distance)
ISH	Integral shutter
LPS300-D	Digital power supply with voltage range 0 - 3 kV
LOA10-AES	Digital AES controller with ramp voltage, sinewave oscillator, lock-in and AES software
LIM12	LEED imaging software with CMOS camera, full version (optional)
LIM12B	LEED imaging software with CMOS camera, basic version (optional)

Control Electronics

LPS075-D Digital LEED

Power supply (0-750 V) with USB interface and PC control software for Windows 10/11. True primary beam current and total emission measurements. Automatic start-up and shut down, 10 memory settings including standby and outgassing mode with timer, constant beam current mode.

LPS300-D Digital LEED-AES

Power supply (0-3.2 kV) with USB interface and PC control software for Windows 10/11. True primary beam current and total emission measurements. Automatic start-up and shut down, 10 memory settings including outgassing with timer, automatic switch from LEED to AES, constant beam current mode.

LOA10-AES

Digital AES controller with lock-in amplifier, AES high voltage ramp board 0-2.0 kV with precision sinewave oscillator (0.5-20 Vpk-pk) and AES software for Windows 10/11. USB communication to PC.

LEED Software

LIM12B

Basic LEED pattern measurements and analysis software and hardware for Windows 10/11 including:

- Automatic LEED pattern acquisition
- CMOS camera
- Flange Mounting kit with ambient light cover and cables

LIM12

Full version LEED pattern measurements and analysis software and hardware for Windows 10/11 including:

- CMOS camera
- Flange mounting kit with ambient light cover and cables
- Software features:
 - Automatic LEED pattern acquisition
 - Automatic I-V analysis with spot tracking
 - Automatic I-T analysis
 - Automatic spot profile analysis

CMOS Camera Specifications

- 12-bit color high-performance video CMOS camera with sensitivity control
- 1/3" CMOS sensor size, 1.6 MP (1440x1080) - sized images, 3.45 μ m pixel size, CS-mount lenses
- Linear Full Well: 9000e-, Dynamic Range: 47 dB

Data

LEED pattern and AES spectrum Si (111) - single crystal wafer after thermal annealing in UHV

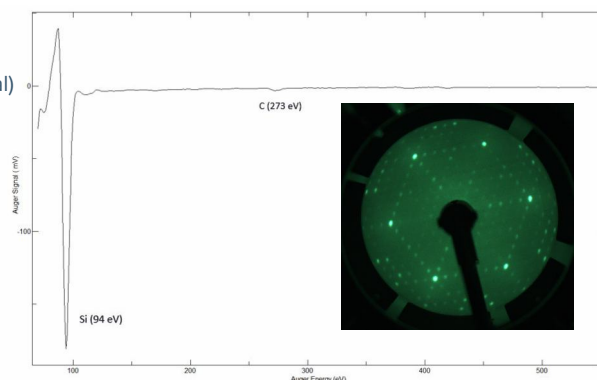

Link for more data:

<http://www.ocivm.com/leed-aes-data.html>

IntegraLEED - MODEL LEED 600

Connection Diagrams

LEED Mode

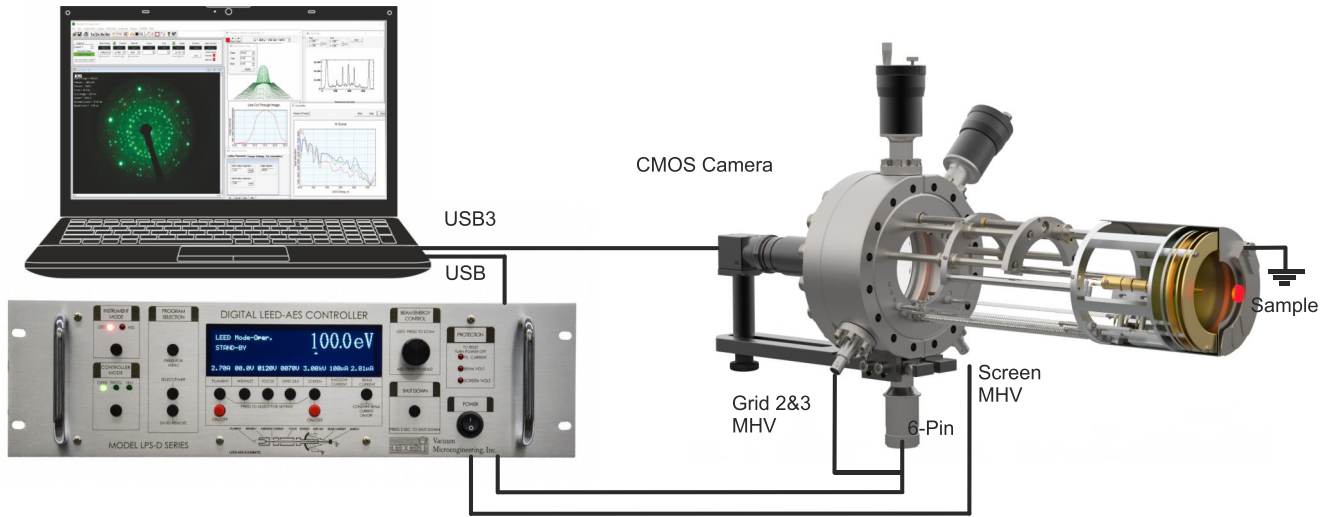

AES Mode

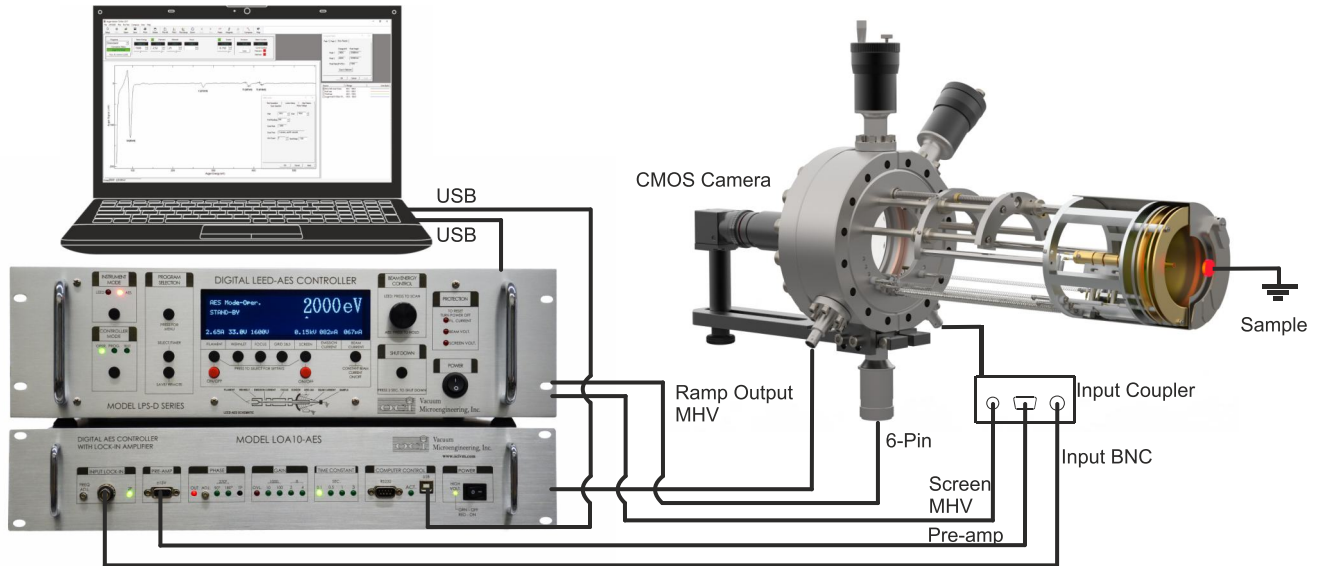

Schematic Drawings

BDL600IR-LMX-ISH SIDE VIEW WITH 100mm RETRACTION

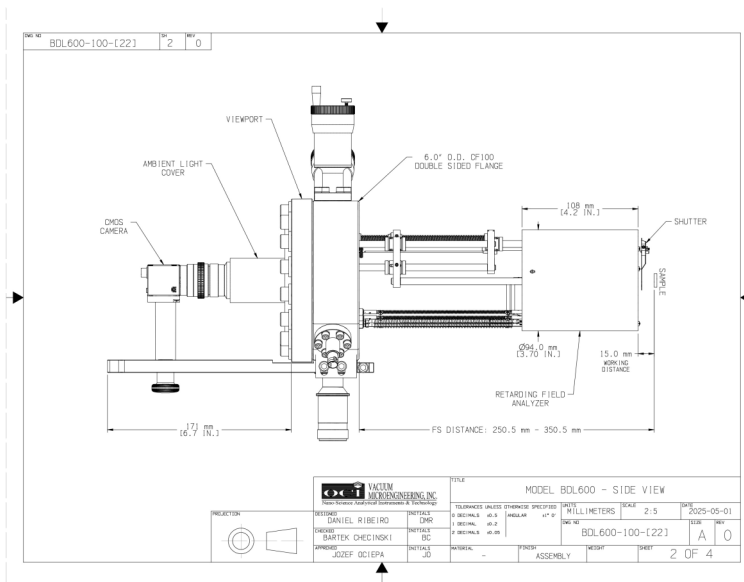

IntegraLEED - MODEL LEED 600

LEED Optics and UHV Chamber Configuration

Calculation formula for Flange-Sample distance and Retraction length:

$$FS = 150.5 \text{ mm} + 2 \text{ LMX} - \text{OV}$$

FS - flange to sample distance
LMX - retraction length
OV - overlapping length

PL - port length
NL - nipple length

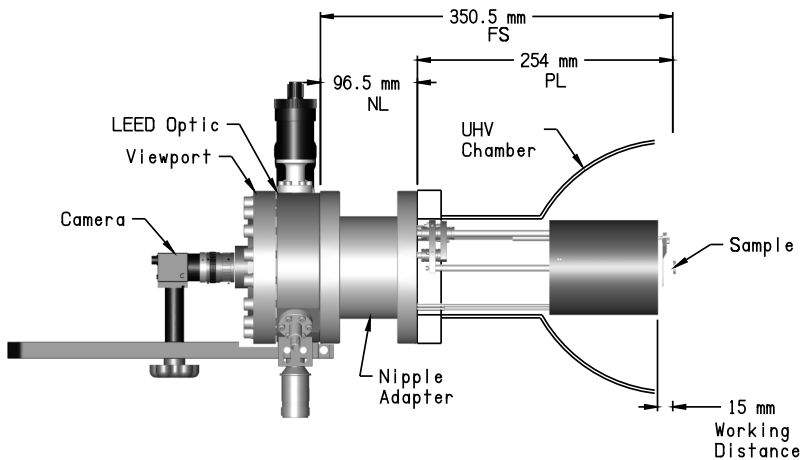

Example:

Operating (working) Position

FS: 350.5 mm PL: 254 mm

LMX: 100 mm NL: 96.5 mm

OV: 0 mm

Schematic Diagrams for 100 mm Retraction

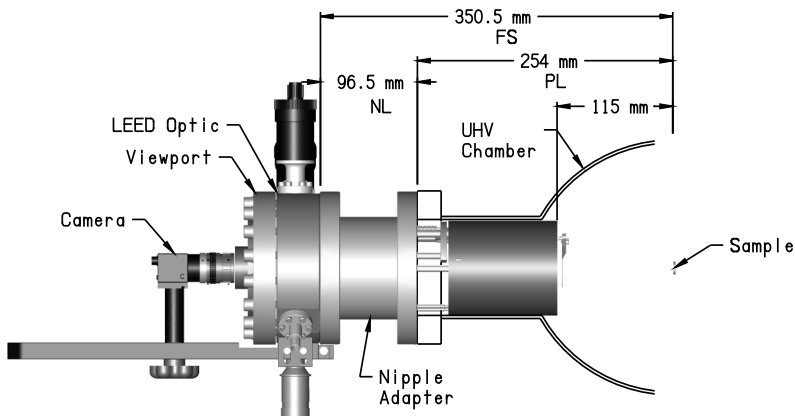

Retracted (parking) Position

FS: 350.5 mm PL: 254 mm

LMX: 100 mm NL: 96.5 mm

OV: 0 mm

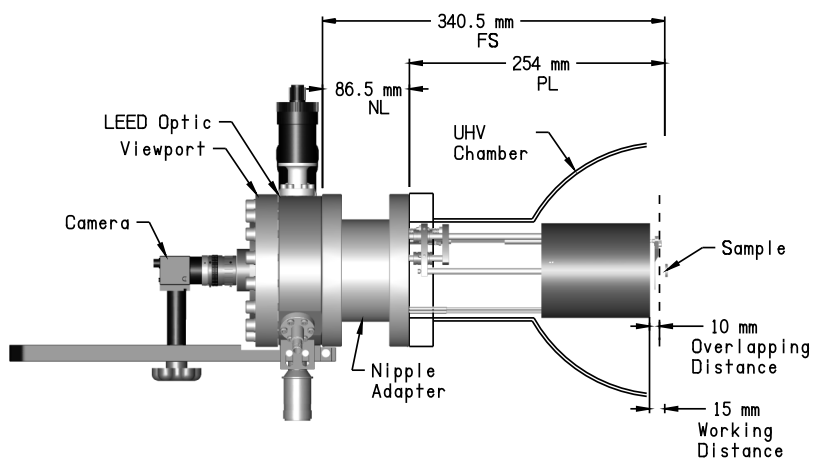

Operating (working)

Position with Overlap

FS: 340.5 mm PL: 254 mm

LMX: 100 mm NL: 86.5 mm

OV: 10 mm