

Surface Crystallography Spectrometer - IntegraLEED

based on Low Energy Electron Diffraction (LEED) and Auger Electron Spectroscopy (AES)
with gain power of Microchannel plates

MODEL LEED 800 MCP (BDL800IR-MCP) with Integral Retraction and Shutter

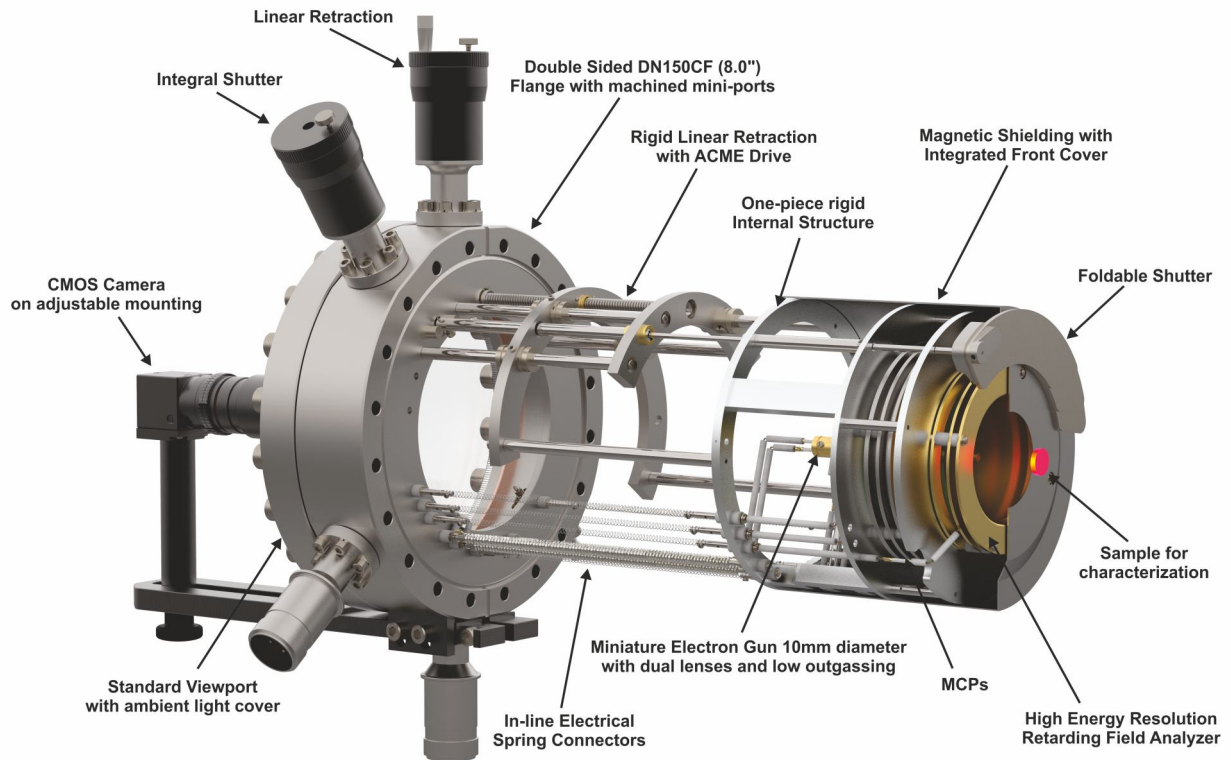

Features:

- High image sensitivity at the primary beam current - 50 pA
- Single/Dual 80 mm Microchannel Plates
- AES at beam current 50 uA - 10 uA
- Miniature Electron Gun with double focusing
- Superior magnetic shielding
- Integral Linear Motion and Shutter
- Suitable for ESDIAD
- Low Outgassing Rate
- Easy add-on AES

Applications

The LEED 800 MCP is designed for very high-sensitivity surface crystallographic and elemental analysis.

Provides precise LEED and AES characterization of delicate epitaxial films, including organic layers, while reducing electron beam damage and preserving structural integrity.

Suitable for surface Debye temperature measurements.

LEED and AES characterization is most effective on well-defined single crystals and epitaxial films. Typical application areas include 2D materials, semiconductor surfaces, metallic and oxide systems, and superconducting and magnetic films.

IntegraLEED - MODEL LEED 800 MCP

Specifications

LEED-AUGER OPTICS (Model BDL800IR-MCP)

Retarding Field Analyzer	Concentric assembly of hemispherical grids Working distance from sample 15mm
Grid Material	Gold coated St-Steel wire mesh (100 mesh, 81% transparency)
Energy Resolution	0.2% - 0.5% at low modulation volt.
Microchannel Plate - single plate	80 mm working area, 25 μ m pore size electron gain - 10^4 - 10^5 , ⁵ spatial resolution - 32 μ m
- chevron	electron gain - 10^6 - 10^7 , ⁷ spatial resolution - 70 μ m
Glass-Display	Fused silica flat plate coated with indium-tin oxide conductive layer and P31 phosphor (ZnS:Ag:Cu-green, 525nm wavelength) 78° angle of acceptance from sample at a distance of 50mm Standard viewport on DN150CF (8"CF) Flange
Monitoring Linear Motion	Up to 150mm retraction from sample (100mm standard); linear ball bearing and acme thread with all spring electrical connections
Integral Shutter Magnetic Shielding	Open and close at any position of the linear motion Mu-metal cylinder with front cover for maximum magnetic field attenuation
Assembly	Extreme-high-vacuum compatibility with stainless steel, high alumina and gold-plated copper alloy materials
Mounting	DN150CF(8"CF) double sided conflat flange with port length range 145mm - 500mm
Bakeability	Under vacuum, 250°C maximum
Integral Miniature Electron Gun	
Beam Energy	LEED 5 eV to 750 eV AES 5 eV to 3000 eV
Beam Current	LEED 2 μ A at 100 eV and 0.5 mm beam size AES up to 100 μ A at 3 keV
Beam Size	from 1 mm to 250 μ m - adjusted by wehnelt voltage
Electron Source	Tungsten-2%Thoriated filament standard, single crystal LaB6 filament optional
Energy Spread	0.45 eV (thoriated-tungsten filament)
Overall Size	10 mm lens diameter and 80 mm length

Ordering Guide

LEED Application:

BDL800IR-MCP	LEED optics with integral electron gun and MCPs on 8" flange - 3 Grids
LMX	Linear motion (X=retraction distance)
ISH	Integral shutter
LPS075-D	Digital power supply with voltage range 0 - 750 V
MCPS1/S2	Controller for microchannel plates with overvoltage and overcurrent protection
LIM12	LEED imaging software with CMOS camera, full version (optional)
LIM12B	LEED imaging software with CMOS camera, basic version (optional)

LEED and AES Application:

BDL800IR-MCP	LEED optics with integral electron gun on 8" flange - 4 Grids
LMX	Linear motion (X=retraction distance)
ISH	Integral shutter
LPS300-D	Digital power supply with voltage range 0 - 3 kV
MCPS1/S2	Controller for microchannel plates with overvoltage and overcurrent protection
LOA10-AES	Digital AES controller with ramp voltage, sinewave oscillator, lock-in and AES software
LIM12	LEED imaging software with CMOS camera, full version (optional)
LIM12B	LEED imaging software with CMOS camera, basic version (optional)

Control Electronics

LPS075-D Digital LEED

Power supply (0-750 V) with USB interface and PC control software for Windows 10/11. True primary beam current and total emission measurements. Automatic start-up and shut down, 10 memory settings including standby and outgassing mode with timer, constant beam current mode.

LPS300-D Digital LEED-AES

Power supply (0-3.2 kV) with USB interface and PC control software for Windows 10/11. True primary beam current and total emission measurements. Automatic start-up and shut down, 10 memory settings including outgassing with timer, automatic switch from LEED to AES, constant beam current mode.

LOA10-AES

Digital AES controller with lock-in amplifier, AES high voltage ramp board 0-2.0 kV with precision sinewave oscillator (0.5-20 Vpk-pk) and AES software for Windows 10/11. USB communication to PC.

MCPS1/S2

Electronics for one or two microchannel plates with digital displays of voltages and MCP load current measurements and protection.

LEED Software

LIM12B

Basic LEED pattern measurements and analysis software and hardware for Windows 10/11 including:

- Automatic LEED pattern acquisition
- CMOS camera
- Flange Mounting kit with ambient light cover and cables

LIM12

Full version LEED pattern measurements and analysis software and hardware for Windows 10/11 including:

- CMOS camera
- Flange mounting kit with ambient light cover and cables
- Software features:
 - Automatic LEED pattern acquisition
 - Automatic I-V analysis with spot tracking
 - Automatic I-T analysis
 - Automatic spot profile analysis

CMOS Camera Specifications

- 12-bit color high-performance video CMOS camera with sensitivity control
- 1/3" CMOS sensor size, 1.6 MP (1440x1080) - sized images, 3.45 μ m pixel size, CS-mount lenses
- Linear Full Well: 9000e-, Dynamic Range: 47 dB

Data

LEED pattern and AES spectrum GaN (0001) - After thermal annealing in UHV

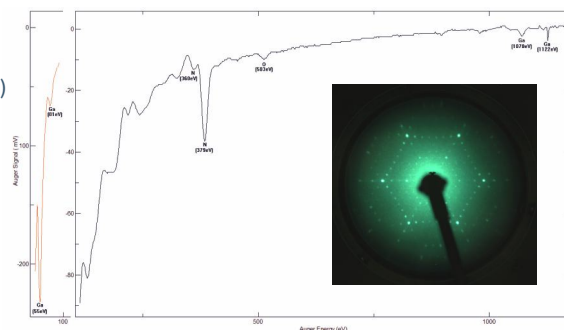

Link for more data:

<http://www.ocivm.com/leedaesdata.html>

IntegraLEED - MODEL LEED 800 MCP

Connection Diagrams

LEED Mode

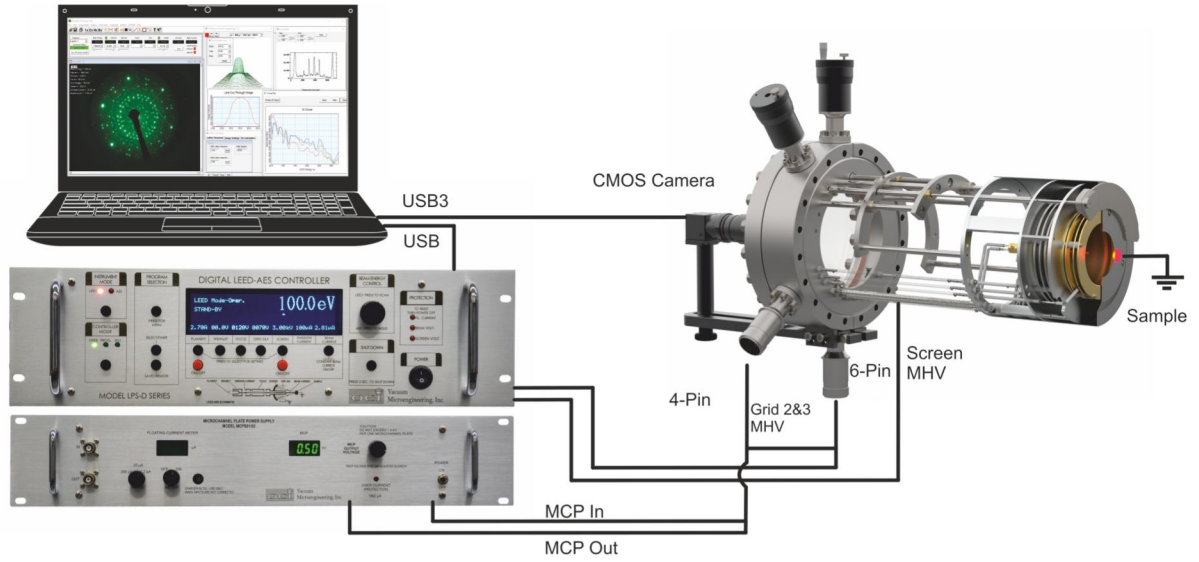

AES Mode

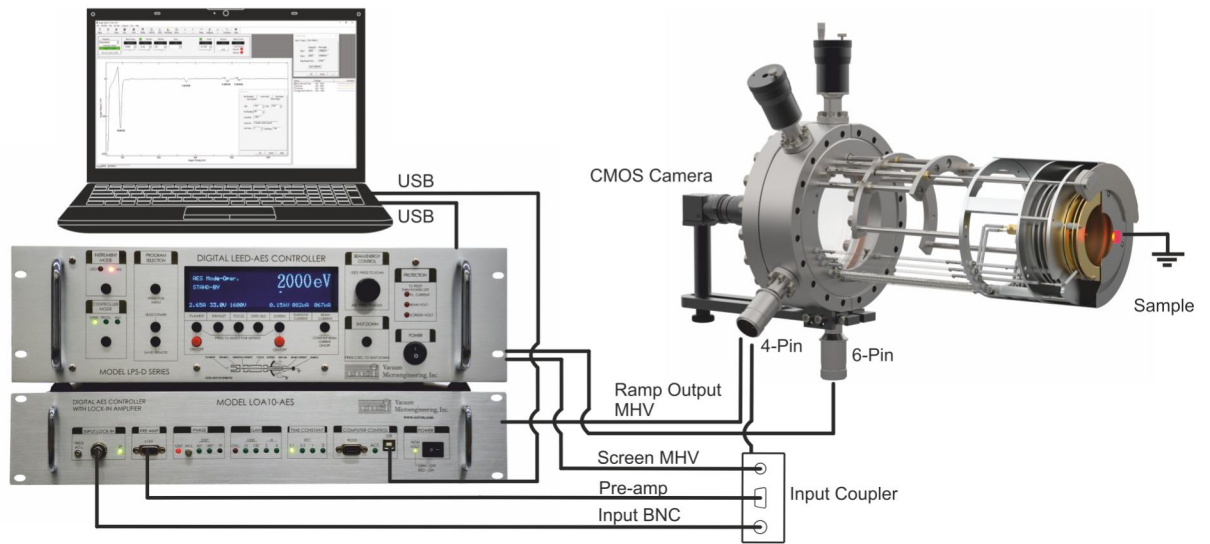

Schematic Drawings

BDL800IR-MCP100DEG SIDE VIEW WITH 100mm RETRACTION

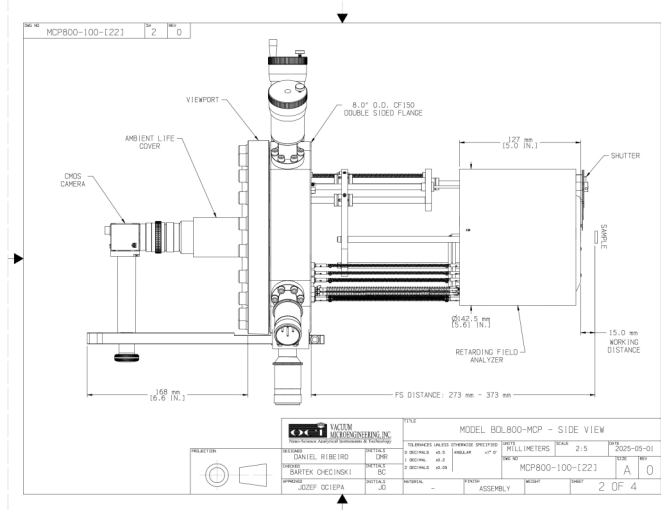

IntegraLEED - MODEL LEED 800 MCP

LEED Optics and UHV Chamber Configuration

Calculation formula for Flange-Sample distance and Retraction length:

$$FS = 173 \text{ mm} + 2 \text{ LMX} - \text{OV}$$

FS - flange to sample distance
 LMX - retraction length
 OV - overlapping length

PL - port length
 NL - nipple length

Schematic Diagrams for 100 mm Retraction

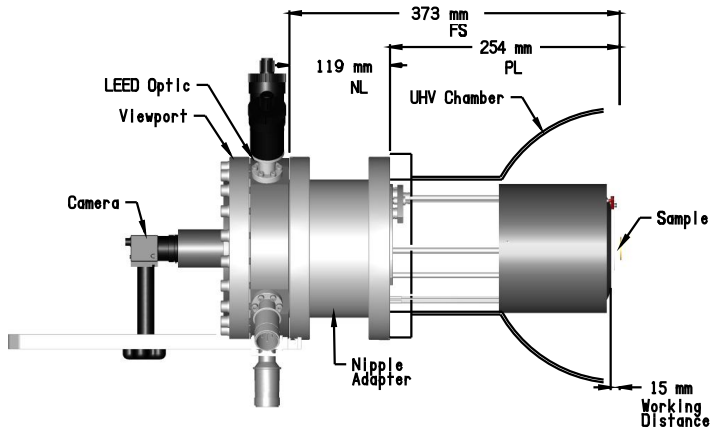

Example:

Operating (working) Position

FS: 373 mm PL: 254 mm
 LMX: 100 mm NL: 119 mm
 OV: 0 mm

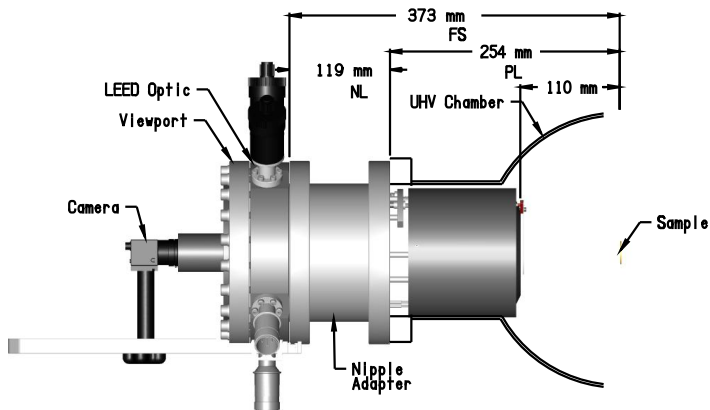

Retracted (parking) Position

FS: 373 mm PL: 254 mm
 LMX: 100 mm NL: 119 mm
 OV: 0 mm

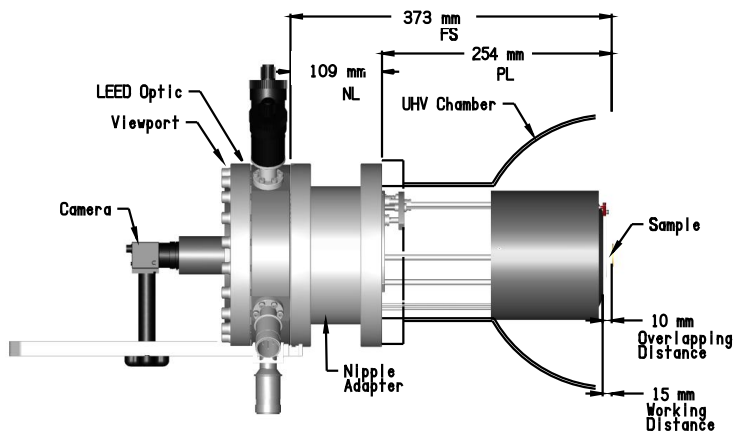

Operating (working) Position with Overlap

FS: 373 mm PL: 254 mm
 LMX: 100 mm NL: 119 mm
 OV: 15mm